

banks

with Installation Instructions
Owner's Manual

**Banks
Straight-Shot[®]
& Double-Shot[®]
*Water-Methanol
Injection Systems***

Vehicle Specific Applications

THIS MANUAL IS FOR USE WITH SYSTEMS 45150, 45151, 45155,
45156, 45160, 45161, 45170, 45171, 45175, 45176, 45180, 45181

Gale Banks Engineering
546 Duggan Avenue • Azusa, CA 91702
(626) 969-9600 • Fax (626) 334-1743

Product Information & Sales: (800) 438-7693
Customer Support: (888) 839-5600
Installation Support: (888) 839-2700

bankspower.com

BANKS

Dear Customer,

If you have any questions concerning the installation of your Banks Straight-Shot® or Double-Shot® system, please call our Technical Service Hotline at (888) 839-2700 between 7:00 am and 4:00 pm (PT). If you have any questions relating to shipping or billing, please contact our Customer Service Department at (888) 839-5600.

Thank you.

General Installation Practices

To avoid serious injury or death, follow the safety information in this document.

1. For ease of installation of your Water-Methanol injection system, familiarize yourself with the procedure by reading the entire manual before starting work. This instruction manual contains 28 pages of text, illustrations and parts listing.
2. Disconnect the ground cable from the battery before beginning work. If there are two batteries, disconnect both.
3. Route and tie wires and hoses a minimum of 6 inches away from exhaust heat, moving parts and sharp edges. Clearance of 8 inches or more is recommended where possible.
4. When raising the vehicle, support it on properly weight-rated safety stands, ramps or a commercial hoist. Follow the manufacturer's safety precautions. Take care to balance the vehicle to prevent it from slipping or falling. When using ramps, be sure the front wheels

are centered squarely on the topsides; put the transmission in park; set the hand brake; and place blocks behind the rear wheels.

⚠ DANGER: Do not use floor jacks to support the vehicle while working under it. Do not raise the vehicle onto concrete blocks, masonry or any other item not intended specifically for this use.

5. During installation, keep your work area and components clean to avoid possible dirt entry into the engine.

6. For proper performance from your Water-Methanol injection system and to prevent engine damage, it is essential that your engine's fuel system be capable of delivering fuel at the factory's specification. We have often found vehicles with inadequate low pressure side fuel delivery that isn't apparent until performance modifications are made.

Definitions of ANSI Z535 Safety Standards

⚠ DANGER: Indicate[s] a hazardous situation which, if not avoided, **will result in death or serious injury.**

⚠ WARNING: Indicate[s] a hazardous situation which, if not avoided, **could result in death or serious injury.**

⚠ CAUTION: Indicate[s] a hazardous situation which, if not avoided, **could result in mild or moderate injury.**

NOTICE: Indicate[s] a situation that requires your immediate attention.

Tools Required:

- 1/4" and 3/8" drive ratchets
- Inch and metric sockets and 3/8" drive extension
- Inch and metric combination or open-end wrenches
- Standard and Phillips head screwdrivers
- Standard and needle-nose pliers
- Pocket or X-Acto knife
- Clean shop towels or rags
- Inch-pound or foot-pound torque wrench
- Electric or pneumatic drill
- Compressed air source and hoses or extension cords
- 1/4", 11/32", and 7/16" drill bits
- 1/8"-27 NPT and 1/4"-18 NPT taps
- Tap handle or equivalent
- Volt meter or multi-meter
- Eye and ear protection
- Permanent marker

Highly recommended tools and supplies:

- Penetrating oil or light lubricant spray
- Center punch and hammer
- Deburr tool
- Compressed air nozzle

Table of Contents

General Installation Practices	2
Tools Required	3
Water-Methanol Injection Introduction and Safety	4
Banks Water-Methanol Injection System Installation	4
Windshield Washer Reservoir	4
Water-Methanol Tank	5
Injection Pump	6
Solenoid	7
Injection Nozzles	8
Plumbing (Straight-Shot®)	12
Plumbing (Double-Shot®)	13
EGT Thermocouple	13
Injection Controller	14
Wiring	15
MAP/TPS Signal Intercept Harness	18
Injection Controller Menu Flow Chart	16
System Setup and Testing	19
Test Drive	25
System Tuning and Nozzle Selection	26
Parts list	27
Appendix A	
Nozzle Flow Rates	28
Appendix B	
Pump Flow Rates	28
Appendix C	
Error Codes & Trouble Shooting	28
Appendix D	
Common Key-on Power Fuse Locations	29

Water-Methanol Injection Introduction and Safety

Banks Water-Methanol injection systems are a reliable and cost effective way to increase power and fuel economy while decreasing exhaust gas temperatures (EGT).

Banks Straight-Shot provides everything you will need for safe and effective Water-Methanol injection. Banks Straight-Shot utilizes your vehicle's windshield washer reservoir as the Water-Methanol tank to save space and reduce cost. Banks Straight-Shot is a fully programmable, single stage injection system that provides a direct shot of Water-Methanol through one or two injection nozzles.

Banks Double-Shot adds second stage injection capabilities controlled by a solenoid. Increased injection control results in increased power and/or fuel economy. Banks Double-Shot also includes a large capacity tank to increase time between fills and accommodates the increased flow volume of two to three nozzles.

Pure methanol is a flammable and volatile fuel, however when diluted with water as in Banks PowerBlend, the mixture becomes much safer. Avoid direct contact with methanol, pure or diluted. If contact with skin occurs, wash contact area thoroughly.

Banks Water-Methanol Injection System Installation

You have been provided with a limited length of 1/4" diameter nylon tubing (P/N 45140) to plumb your Banks Water-Methanol injection system, take care while determining the location of system components. If needed, extra nylon tubing can be purchased from Banks Power by calling (800) 601-8077.

Take care while determining the location of Water-Methanol injection components that require power and/or signal as the wire lengths of the wire harness were designed for components mounted in the engine compartment.

Windshield Washer Reservoir

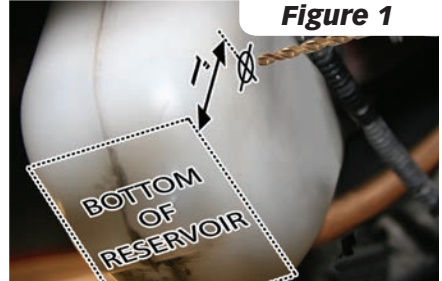

Figure 1



Figure 2

NOTICE: Drilling and tapping your windshield washer fluid reservoir is only necessary for the Straight-Shot system. If you have purchased the Double-Shot system, proceed to the Water-Methanol Tank section.

1. Locate your windshield washer fluid reservoir and drain all fluid by removing the supply line at bottom of reservoir.
2. Use a permanent marker to mark location where reservoir will be drilled. Choose a location approximately 1" above lowest point of reservoir where there will be no interference with the addition of a fitting and tubing. See **Figure 1**

3. Remove windshield washer fluid reservoir from vehicle for better access when drilling and tapping.

4. Use a center punch to mark the hole location and keep the drill bit from wandering. Use 7/16" drill bit to drill a hole at marked location. Drill perpendicular to reservoir surface to avoid leaks.

5. Use 1/4"-18 NPT tap to thread windshield washer fluid reservoir. Ensure tap is perpendicular to reservoir surface to avoid leaks. Check the thread depth as you tap by periodically removing the tap and screwing the 90° male push-lock (P/N 45121) fitting into the tapped hole. The fitting should thread in 3 to 3½ turns hand tight. Do not install the fitting in place at this time.

⚠ CAUTION: Running the tap too deeply can prevent fitting from properly sealing.

6. Thoroughly clean inside of reservoir to remove all debris.

7. Thread 90-degree male Push-Lock fitting into reservoir. Tighten 2-3 turns past hand tight. Do not over tighten. See **Figure 2**

8. Add enough water in reservoir to check for leaks around fitting. Drain water and reinstall windshield washer fluid reservoir.

Water-Methanol Tank

NOTICE: A large capacity tank (P/N 45095-45098) is only provided in the Double-Shot system. Proceed to the Injection Pump section if you purchased the Straight-Shot system.

Figure 3



1. Determine where tank will be mounted so that it will not interfere with moving or hot engine components. **DO NOT** mount tank inside vehicle where there are passengers. Test fit tank (P/N 45095-45098) with mounting straps (P/N 91590-91592) at desired location. Use a permanent marker to mark where straps will be mounted. Ensure that the desired location will not interfere with vehicle operation and that drilling at this location for mounting will be safe. See **Figure 3**

⚠ CAUTION: Take care while drilling and know what is behind the piece you are drilling through. Note the location of the fuel tank, fuel lines, wiring, etc.

Figure 4



2. Use a center punch to mark the hole location and keep the drill bit from wandering. Use 1/4" drill bit to drill necessary holes where marked to mount the tank mounting straps. Deburr sharp edges. See **Figure 4**

⚠ WARNING: Use eye and ear protection while drilling.

Figure 5



3. Thread 90-degree male Push-Lock fitting (P/N 45121) into threaded bung of tank. Tighten 2-3 turns past hand tight. Do not over tighten. Add enough water in reservoir to check for leaks around fitting. See **Figure 5**

4. Drain water and use provided mounting straps, bolts (P/N 91120), nuts (P/N 91110), and washers (P/N 91103) to mount tank where desired. See **Figure 6**

Figure 6



Injection Pump

NOTICE: Injection pump (P/N 45030 or 45031) can be mounted in any orientation, but is flow directional. The head unit is labeled with an arrow to show flow direction. Take care while determining the mounting location in your vehicle. See **Figure 7**

Figure 7

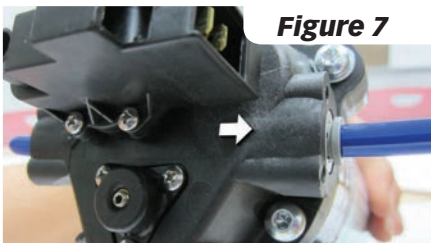

1. Determine where pump will be mounted so that it will not interfere with moving or hot engine components and will avoid spray and debris from tires. Use pump bracket as a template to mark where bracket will be mounted. Ensure that the desired location will not interfere with vehicle operation and that drilling at this location for mounting will be safe. See **Figure 8**

Figure 8

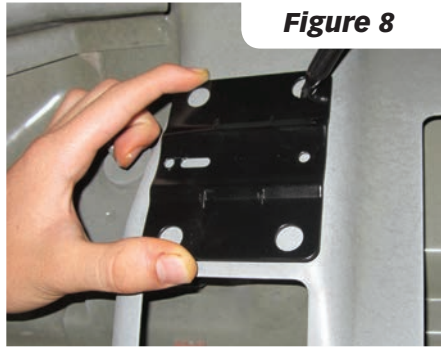

CAUTION: Take care while drilling and know what is behind the piece you are drilling through. Note the location of the fuel tank, fuel lines, wiring, etc.

2. Use a center punch to mark the hole locations and keep the drill bit from wandering. Use a 1/4" drill bit to drill the necessary holes where marked to mount pump bracket. Deburr sharp edges.

WARNING: Use eye and ear protection while drilling.

Figure 9

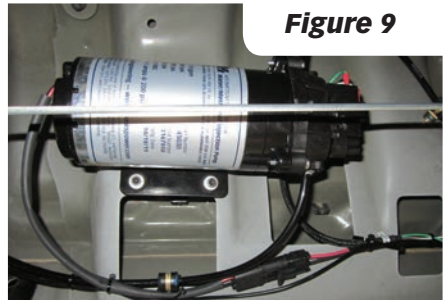

3. Use provided bolts (P/N 91761), nuts (P/N 91771), and washers (P/N 91102) to mount pump in your truck. Tighten until nylon locking feature is fully engaged and rubber grommet is compressed at least 1/8." Do not over tighten or damage to grommets will occur. See **Figure 9**

Solenoid

NOTICE: A solenoid (P/N 45035) is only provided in the Double-Shot system. Proceed to the Injection Nozzle(s) section if you purchased the Straight-Shot system.

NOTICE: Solenoid must be mounted upright and is flow directional with the ports labeled "IN" and "OUT". Take care while determining the mounting position in your vehicle. See **Figures 10 and 11**.

Figure 10



Figure 11



1. Determine where the solenoid will be mounted so that it will not interfere with moving or hot engine components and will avoid spray and debris from tires. Use solenoid bracket (P/N 45038) as a template to mark

where the bracket will be mounted. Ensure that the desired location will not interfere with vehicle operation and that drilling at this location for mounting will be safe. See **Figure 12**

Figure 12



CAUTION: Take care while drilling and know what is behind the piece you are drilling through. Note the location of the fuel tank, fuel lines, wiring, etc.

2. Use a center punch to mark the hole location and keep the drill bit from wandering. Use a 1/4" drill bit to drill necessary holes where marked to mount solenoid bracket. Deburr sharp edges. See **Figure 13**

Figure 13



WARNING: Use eye and ear protection while drilling.



Figure 14

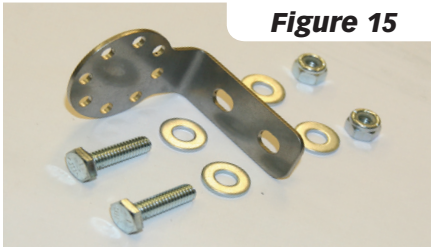

Figure 15

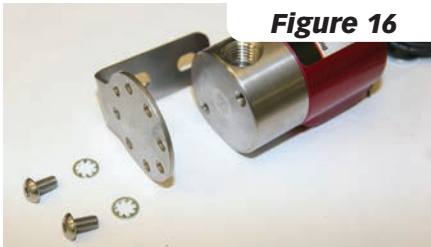

Figure 16

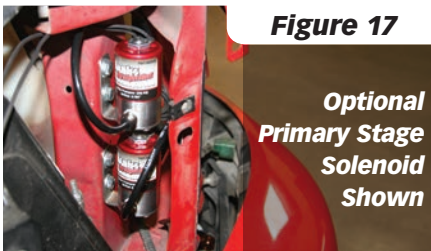

Figure 17

*Optional
Primary Stage
Solenoid
Shown*

3. Thread straight Push-Lock fittings (P/N 45120) into both ports of solenoid. Tighten two turns past hand tight. See **Figure 14**
4. Use provided bolts (P/N 91118), nuts (P/N 91110), and washers (P/N 91102) to mount solenoid bracket in your vehicle. See **Figure 15**
5. Use provided screws (P/N 91725) and washers (P/N 91826) to mount the solenoid onto solenoid bracket. See **Figure 16 and 17**

Injection Nozzle(s)

NOTICE: If your vehicle is equipped with a late model Banks Monster Ram, you do not have to drill and tap your intake duct as the Monster Ram has the proper threaded ports.

1. Injection nozzle(s) (P/N 45081-45090) should be mounted in your air intake duct, post-intercooler (if equipped) and approximately 6" before throttle body (if equipped) where possible. When engine is cool, mark the location on your air intake duct where injection nozzle(s) will be installed so that they will not interfere with moving or hot engine components.

NOTICE: If installing multiple injection nozzles, we recommend separating the injection nozzles by at least 3" to avoid crossing spray patterns. See **Figure 18**

2. Remove air intake duct and cover engine and intake tube with clean rags to avoid getting debris into your engine.

CAUTION: Intake duct can be drilled and threaded while on engine **ONLY** if you can ensure that no debris will enter engine or intake tube. We highly recommend removing intake duct from vehicle.

3. Use a center punch to mark the hole locations and keep the drill bit from wandering. Use a 11/32" drill bit to drill a hole at marked location(s). Drill perpendicular to the intake duct surface to ensure injection nozzle(s) will spray perpendicular to intake airflow direction. Deburr sharp edges. See **Figure 23**

4. Use 1/8"-27 NPT tap to thread air intake duct. Ensure tap is perpendicular to air intake duct surface to avoid leaks. Check the thread depth as you tap by periodically removing the tap and screwing the injection nozzle into the tapped hole. The injection nozzle should thread in 3 to 3½ turns hand tight. Do not install the injection nozzle in place at this time. See **Figure 24**

Figure 19

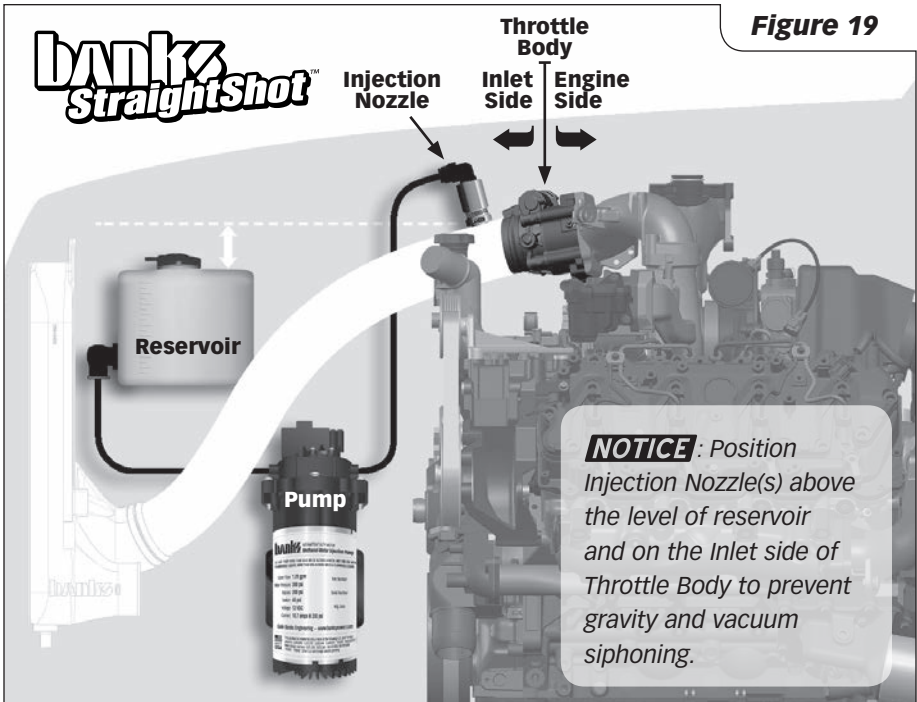
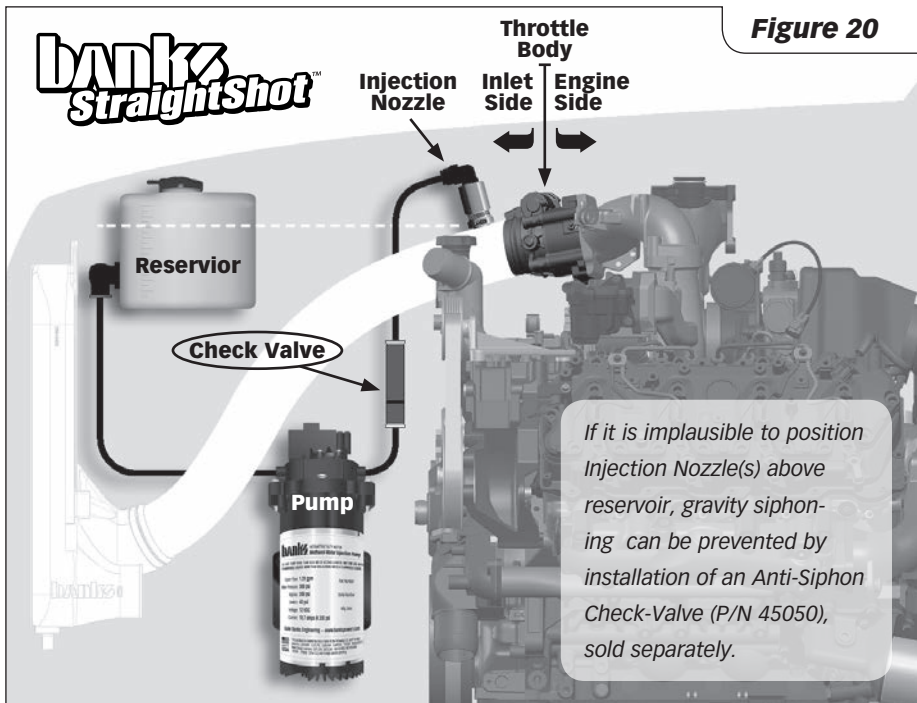
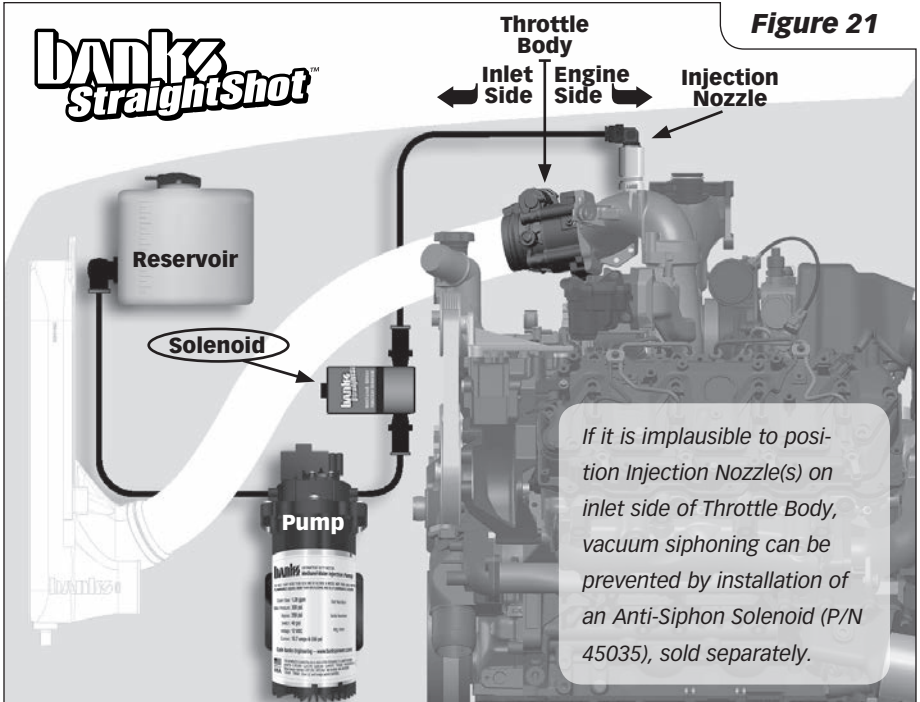

Figure 20



banks
StraightShot™

Figure 21



banks
DoubleShot™

Figure 22

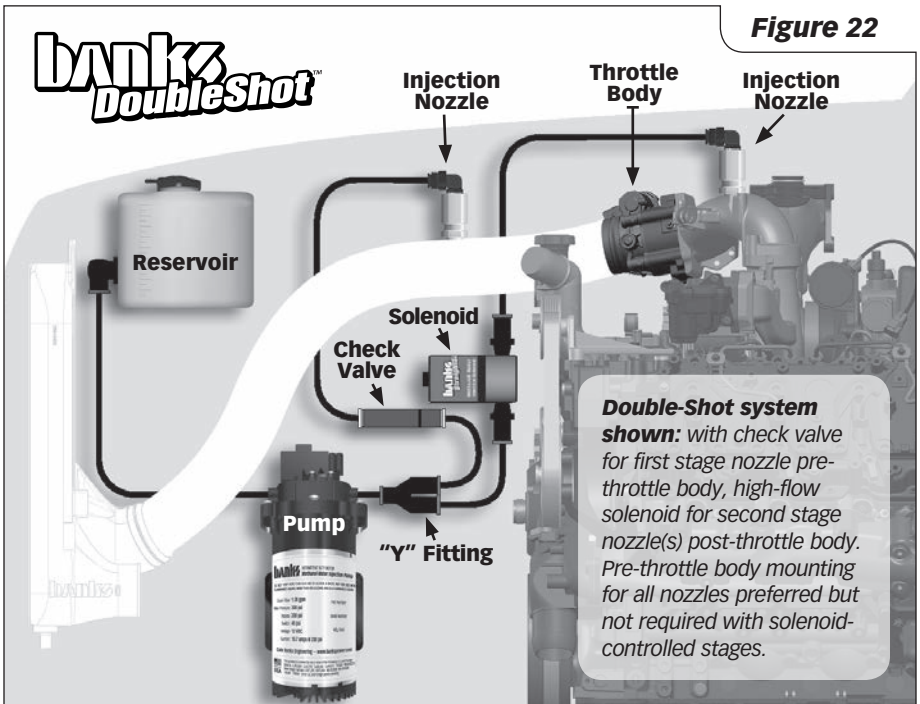
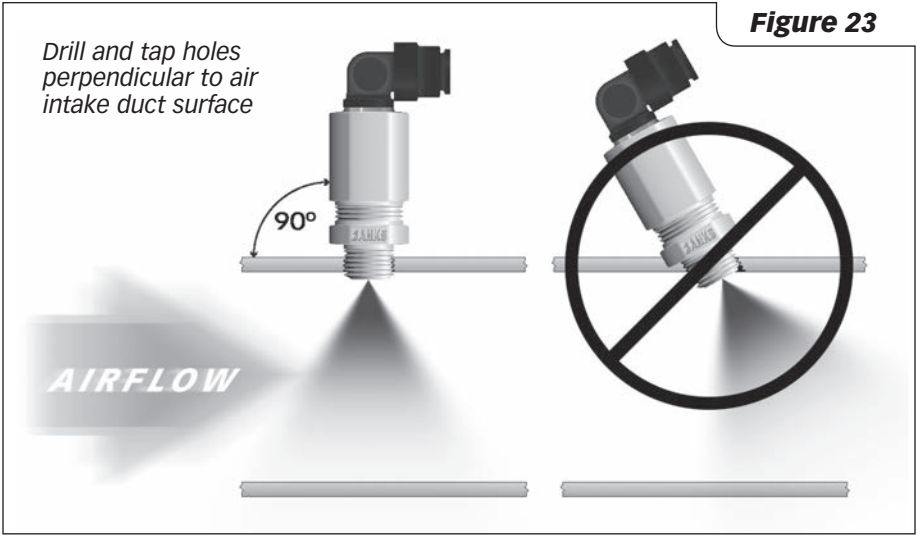

Figure 23



⚠ CAUTION: Running the tap too deeply can prevent injection nozzle(s) from properly sealing.

5. Apply provided sealant tape (P/N 91099) to threads of injection nozzle(s) to be used and thread each injection nozzle into a 90-degree female Push-Lock fitting (P/N 45122). Tighten 2-3 turns past hand-tight. See **Figure 25**

⚠ CAUTION: Sealant tape must be applied properly to avoid leaks.

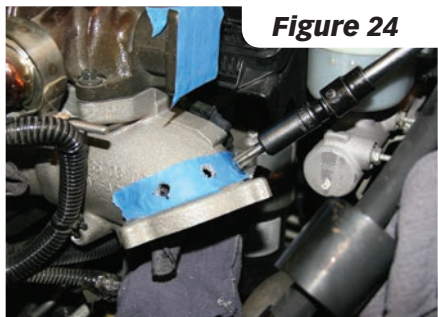

Clean threads with rag. Start at second thread in from end. Wrap tightly following direction of threads to avoid tape peeling away from Injection Nozzle when threaded into fitting. Overlap tape, moving towards base of threads creating two layers of sealant tape. See **Figure 26**

Figure 25

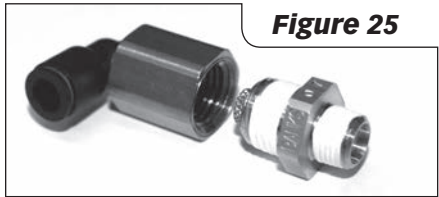

6. Thread Injection Nozzle assembly into the air intake duct. Cover open end of the 90-degree Push-Lock fitting to avoid debris entering intake duct. See **Figure 27**

Plumbing (Straight-Shot)

NOTICE: If you purchased the Double-Shot system proceed to the Plumbing (Double-Shot) section.

⚠ CAUTION: Route and secure tubing where it will not interfere with moving or hot engine components. Avoid sharp turns that may kink tubing and sharp edges that



may damage tubing.

⚠ CAUTION: Cut tubing using a Pocket or X-Acto knife to avoid pinching the tubing. Pinching the tubing will cause it to not seat properly.

1. Secure one end of 1/4" Nylon tubing (P/N 45140) into Push-Lock fitting on windshield washer fluid reservoir by firmly pushing tubing into Push-Lock fitting.

Carefully pull on tubing to ensure tubing is secured properly.

2. Route tubing to injection pump inlet. Cut tubing, allowing approximately 1/2" for securing into injection pump. Properly secure tubing into injection pump inlet. See **Figure 28**

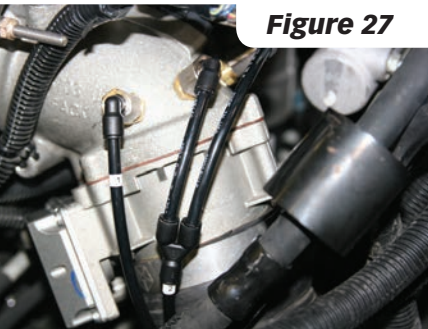

Figure 27

Figure 28

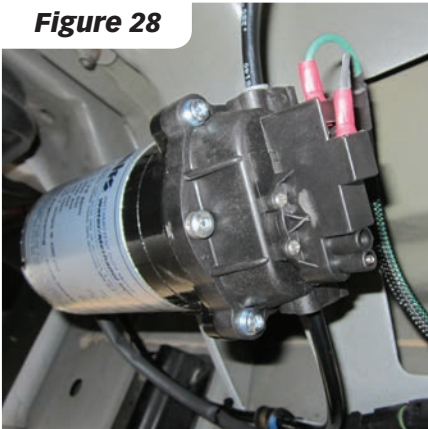

Figure 29

⚠ CAUTION: Make all cuts as square as possible to avoid leaks.

3. For a single injection nozzle, secure and route tubing from pump outlet to injection nozzle assembly in intake duct. Properly cut tubing and secure into injection nozzle assembly.

4. For two injection nozzles, secure and route tubing from pump outlet to port #1 of "Y" fitting (P/N 45123). Properly cut tubing and secure into "Y" fitting. See **Figure 29**

NOTICE: Determine where you want Push-Lock "Y" fitting located and route tubing appropriately. Choose a location that is easily accessible and can be checked for leaks.

4a. Secure tubing in port #2 of "Y" fitting and route tubing to first injection nozzle assembly. Properly cut tubing and secure into injection nozzle assembly.

4b. Repeat step 4a for second injection nozzle assembly using port #3 on the "Y" fitting.

5. Use tie wraps to secure all tubing.

Plumbing (Double-Shot)

NOTICE: Route and secure tubing where it will not interfere with moving or hot engine components. Avoid sharp turns that may kink tubing and sharp edges that may damage tubing.

⚠ CAUTION: Cut tubing using

a Pocket or X-Acto knife to avoid pinching the tubing. Pinching the tubing will cause it to not seat properly.

1. Secure one end of 1/4" Nylon tubing (P/N 45140) into Push-Lock fitting on high capacity tank by firmly pushing tubing into Push-Lock fitting. Carefully pull on tubing to ensure tubing is secured properly.

2. Route tubing to injection pump inlet. Cut tubing, allowing approximately 1/2" for securing into injection pump. Properly secure tubing into injection pump inlet.

⚠ CAUTION: Make all cuts as square as possible to avoid leaks.

3. Route tubing from injection pump outlet to port #1 of "Y" fitting (P/N 45123). Properly cut tubing and secure into "Y" fitting. See **Figure 29**

4. Secure tubing in port #2 of "Y" fitting and route tubing to inlet of check valve. Properly cut and secure tubing in Push-Lock check valve. See **Figure 30**

Figure 30



5. Secure tubing in port #3 of "Y" fitting and route tubing to "IN" port of solenoid. Properly cut and secure tubing in Push-Lock on solenoid.

6. Secure tubing in outlet of check valve and route to the first injection nozzle assembly. Properly cut tubing and secure into injection nozzle assembly.

7. For two injection nozzles, secure tubing in Push-Lock fitting of solenoid labeled "OUT" and route to the second injection nozzle assembly. Properly cut tubing and secure into injection nozzle assembly.

8. For three injection nozzles, secure tubing in Push-Lock fitting of solenoid labeled "OUT" and route to port #1 of "Y" fitting (P/N 45123). Properly cut tubing and secure in "Y" fitting. Secure tubing in port #2 of "Y" fitting and route tubing to the second injection nozzle assembly. Properly cut tubing and secure into injection nozzle assembly. Repeat for the third injection nozzle assembly using the #3 port of the "Y" fitting.

EGT Thermocouple

NOTICE: An EGT thermocouple (P/N 63042) is only provided in the Double-Shot system. If you purchased the Straight-Shot system, proceed to the Wiring and Controller section. See **Figure 31**

1. The thermocouple monitors the temperature of the exhaust gases entering the turbocharger at the turbine housing. Installation requires that the exhaust manifold be drilled near the manifold outlet. It is recommended that the manifold be removed from the engine to thoroughly clean out all metal chips from drilling. All metal shavings must be cleaned from the manifold to avoid turbine wheel damage.

2. Mark location on exhaust manifold (pre-turbo) where EGT thermocouple will be mounted so that it will not interfere with any engine components.

3. Remove exhaust manifold and cover the exhaust ports and up-pipe to avoid debris entering engine or exhaust system.

4. Drill a 7/16" hole in exhaust manifold at marked location perpendicular to manifold surface. Deburr sharp edges.

5. Tap the hole for a 1/4" NPT thread. Check the thread depth as you tap by periodically removing the tap and screwing the pipe

coupling into the tapped hole. The coupling should thread in 3 to 3½ turns hand tight. Do not install the probe in place at this time.

⚠ CAUTION: Running the tap too deeply can prevent the pipe fitting from properly sealing.



Figure 31

6. Thoroughly clean exhaust manifold with solvent to remove any debris and reinstall exhaust manifold on engine.

⚠ CAUTION: Failure to remove all metal chips could result in catastrophic damage to the turbocharger's turbine wheel.

7. Remove the NPT fitting from the thermocouple and install it on the exhaust manifold. Use supplied anti-seize lubricant on the threads and torque to 14–16 lb-ft.

8. Reinstall the exhaust manifold. Apply anti-seize lubricant to the manifold bolt threads and torque as specified in service manual.

9. Install thermocouple in fitting on exhaust manifold. See **Figure 32**

Injection Controller

NOTICE: A basic mounting panel is provided to mount injection con-

troller. Other mounting options, including A-pillar pod mounts, are available through Banks Power for vehicle specific mounting. See **Figure 33**

Figure 33

1. Determine where the injection controller (P/N 45020 or 45021) will be mounted using mounting panel (P/N 63001) and controller bracket (P/N 63006) where it will not interfere with driving operations.

⚠ CAUTION: Take care when installing the mounting panel as to not damage anything critical with fasteners.

2. Install the mounting panel using supplied fasteners.

3. Install injection controller in mounting panel and secure using controller bracket.

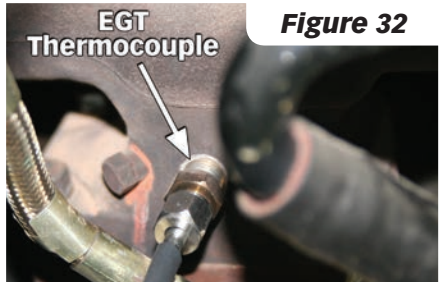

Figure 32

Wiring

NOTICE: Route and secure wiring where it will not interfere with moving or hot engine components (along OEM wiring where possible). Avoid sharp edges that may damage wiring.

1. Using provided system schematics, find connectors for injection controller on the pump harness (P/N 62831) and signal harness (P/N 62832). Carefully feed these connectors and boost reference hose (P/N 94445) through firewall grommet (usually located underneath dash) to injection controller. See **Figure 34**

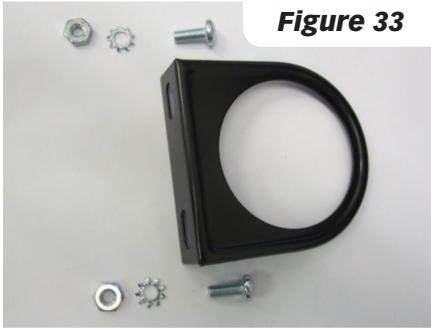

Figure 33

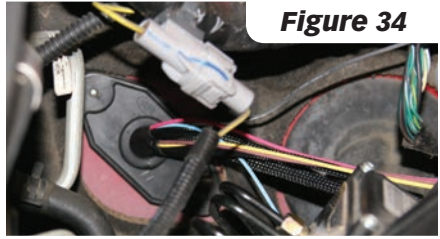

Figure 34

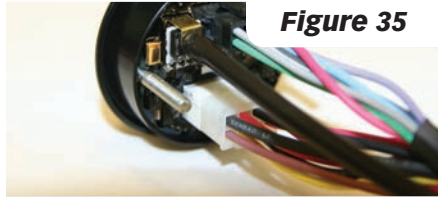

Figure 35

2. Connect both 8-pin connectors to controller where appropriate. Connect 2-pin connector for EGT thermocouple, if equipped. See **Figure 35**

3. Secure boost reference hose to reference port barb on back of injection controller using the 3/32" hose (P/N 94118) as an adapter between the boost reference hose and the reference port barb. See **Figure 36**

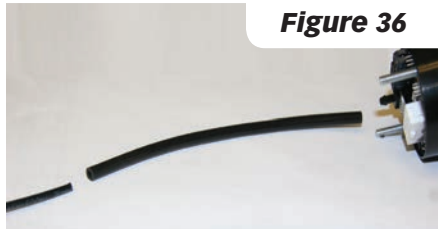

Figure 36

4. Route appropriate connectors of signal harness to respective Water-Methanol injection components and fasten connectors. Use provided system schematics for reference. Secure wiring with tie wraps.

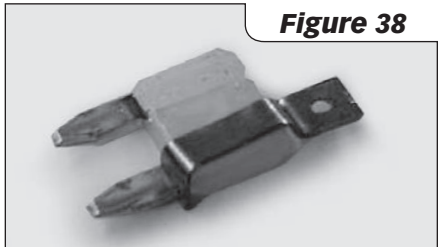

Figure 38

5. Route appropriate connectors of pump harness to respective Water-Methanol injection components and fasten connectors. Use provided system schematics for reference. Secure wiring with tie wraps.

6. Use the provided list of fuse locations (Appendix D, pg. 29) or a multimeter to find a fuse with key-on power for the injection controller. Connect the fuse tap for the injection controller. See **Figures 38 & 39**

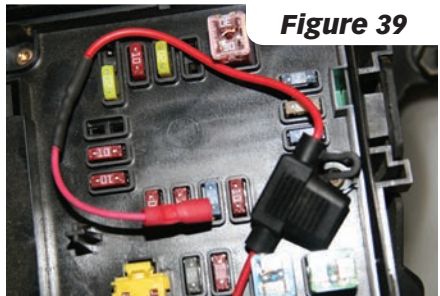
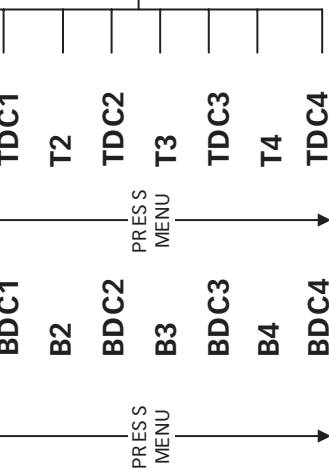

Figure 39

7. Fasten all other connectors and terminals (power supplies, ground leads, etc.) of pump and signal harnesses to appropriate locations, using system schematics for reference. Secure wiring with tie wraps.



Set desired value using menu button to scroll and select button to make selection.

- BX - BOOST REFERENCE VALUE X
- BDCX - BOOST DUTY CYCLE X
- BST - BOOST
- D5.9 - DODGE 5.9L
- D6.7 - DODGE 6.7L
- DISP - DISPLAY
- E+B - EGT AND BOOST
- E+T - EGT AND THROTTLE
- EDCX - EGT DUTY CYCLE X
- EGT - EXHAUST GAS TEMPERATURE
- EGTX - EGT REFERENCE VALUE X
- F6.0 - FORD 6.0L

- F6.4 - FORD 6.4L
- INPT - INPUT
- INT - INTERNAL
- MAP - MANIFOLD ABSOLUTE PRESSURE
- OCTL - OUTPUT CONTROL
- PDC - PUMP DUTY CYCLE
- S2ST - SOLENOID #2 STATUS
- TX - THROTTLE REFERENCE VALUE X
- TDCX - THROTTLE DUTY CYCLE X
- THRT - THROTTLE
- VER - VERSION

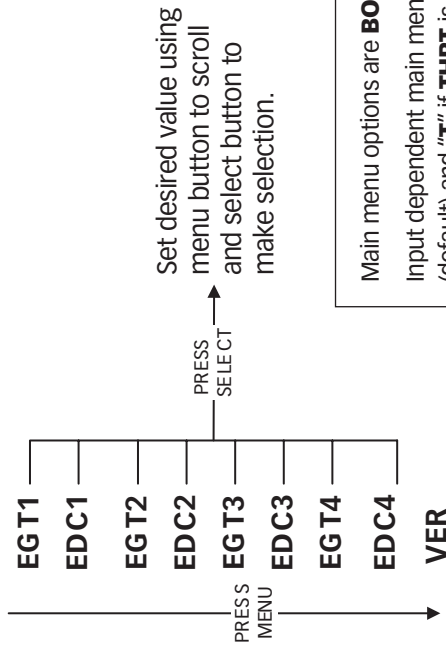

Set desired value using menu button to scroll and select button to make selection.

Main menu options are **BOLD**.

Input dependent main menu selection displays "**B**" if **MAP** is selected for input (default) and "**T**" if **THRT** is selected for input.

OPTIONS E___ will only display if equipped with EGT thermocouple.

OPTIONS ___**3** and ___**4** will only display if equipped with secondary solenoid.

MAP/TPS Signal Intercept Harness

NOTICE: A vehicle specific MAP/TPS signal intercept harness (pigtail harness) is only included in vehicle specific methanol-water injection systems. If you purchased a universal methanol-water injection system, proceed to the System Testing and Setup section. Based on the desired injection controller input (boost or throttle), the MAP or TPS signal must be intercepted and sent to injection controller. For boost based systems, the MAP signal must be intercepted. For throttle based systems, the TPS signal must be intercepted.

Certain supported vehicles use the OEM MAP or TPS sensor with a pigtail harness to intercept the desired signal.

For supported vehicles:

1. Locate the MAP or TPS sensor on your vehicle, depending on the desired input mode. Disconnect the OEM wire harness by releasing locking mechanism. A small standard screwdriver can be used to release locking mechanism, if necessary. See **Figure 40**

2. Connect pigtail harness (See Parts List for P/Ns) to MAP or TPS sensor and check for full engagement of locking mechanism. See **Figure 41**

3. Connect OEM wire harness to pigtail harness and check for full engagement of locking mechanism. See **Figure 42**

4. Connect 1-pin male connector to the blue lead of signal harness and check for full engagement of locking mechanism. See system schematic for reference. See **Figure 43**

NOTICE: Route and secure wiring where it will not interfere with moving or hot engine components (along

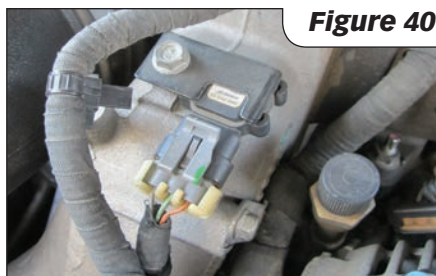

Figure 40

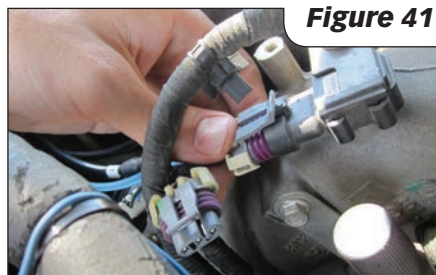

Figure 41

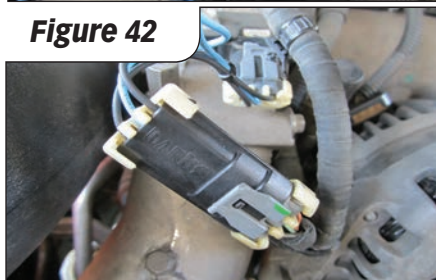

Figure 42

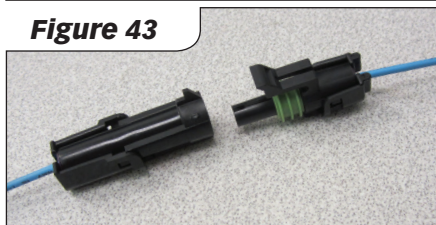

Figure 43

OEM wiring where possible). Avoid sharp edges that may damage wiring.

System Testing and Setup

NOTICE: Use "MENU" button on injection controller to scroll through a menu and "SELECT" button to choose a menu option. See injection control-

ler menu flow chart (pages 16-17) for an overview of controller menus.

⚠WARNING: This section of the manual will walk you through the initial purging and pressure test process to ensure that your installation is clean and leak-free. It is critical to safe system operation that each step be followed in order, and that any leaks are corrected before vehicle operation.

1. Fill windshield washer fluid reservoir or high capacity tank with distilled water.

2. Turn vehicle ignition to on without starting the vehicle. The injection controller screen should light up and scroll "BANKS POWER" along with the controller software version number.

3. Remove tubing from each injection nozzle assembly by pressing in the collar of the push-lock fitting and gently pulling

on tubing. Place end(s) of tubing into a clear container of suitable size (the high volume pump can move more than a gallon of water a minute) and secure container in a stable position.

⚠CAUTION: Tubing must be disconnected from injection nozzle assembly while priming pump, otherwise water could flood and damage engine.

4. Temporarily disconnect the pump pressure switch connector from the signal harness, or remove one pump pressure switch lead from the pump. Now, the system may be primed and purged by using the injection controller's "TEST" mode. To activate "TEST" mode:

4a. Scroll through the main menu by pressing the "MENU" button. Press the "SELECT" button to select the "OCTL" (output control) sub-menu.

4b. Scroll through the "OCTL" sub-menu by pressing the "MENU" button. Press the

"SELECT" button to select and activate "TEST" mode. Any connected solenoids will open, the pump will turn on and run at 50% duty cycle for 6 seconds, and then turn off automatically. Let the test mode run until water flows out of tubing into clear container, and then turn it off by selecting "OFF" from the "OCTL" menu.

4c. If there is debris present in the container after running the initial test, re-fill the system tank with clean distilled water and repeat "TEST" mode until all debris remaining from installation has been purged from the system. Check all tubing connections for leaks.

⚠NOTICE: If the controller displays an error code, or the pump does not turn on when activating "TEST" mode, refer to the error code index (page 27) and use system schematic (P/N 97650-A or 97651-A) to ensure all components were connected to appropriate connectors. Check all connectors for full engagement. If pump turns on, but water does not flow out of tubing, use system schematic (P/N 97650-A or 97651-A) to ensure system was plumbed correctly.

4d. Remove all injector nozzle(s) from their mounting ports on the engine and re-connect them to their supply tubes. Empty water from the clear container used in the previous step, insert the assembled injector nozzles and supply lines back into the container and re-secure in a stable position.

4e. Initiate another "TEST" mode from the injection controller and examine the spray pattern from each nozzle. A clean, evenly-distributed spray cone should be visible from every nozzle (some moderate pulsation is normal and will vary based on nozzle selection). Examine the threaded joint between each nozzle and nozzle holder carefully for any leaks during this high pressure test - tighten the assembly

Figure 44



in quarter turn steps until corrected.

4e. Dribbling or spitting from one or more nozzles while other nozzles atomize properly indicates a partially plugged nozzle or filter - exit "TEST" mode, remove the nozzle from the holder fitting. Use pliers to unscrew screen holder and examine the screen for debris. **4g.** If no leaks are noted and each nozzle is atomizing correctly, exit "TEST" mode and turn off the vehicle's ignition switch to power down the injection controller.

5. Double-check tubing and all connections for leaks. Permanently install injection nozzles and tubing into appropriate locations, and reconnect pump pressure switch.

NOTICE: To setup the StraightShot injection controller for first-time use, several selections needs to be made for the controller to configure it for your specific application.

6. Turn vehicle ignition to on without starting the vehicle. Select the "INPT" (input) sub-menu using "MENU" button to scroll through main menu and "SELECT" button to select "INPT". Scroll through the "INPT" menu and select "MAP" (Manifold Absolute Pressure) for boosted applications or "THRT" (throttle) for non-boosted applications. "MAP" is the default input method, and requires that a specific MAP

sensor type be selected (in the following step). If "THRT" mode is selected, no further input configuration is required - the controller will display throttle value from 0-100% based on a 0.5V-4.5V range.

NOTICE: Main menu, "OCTL" submenu, and "DISP" sub-menu will display different options based on the selected "INPT" mode. If "MAP" is selected, the main menu will display boost reference values and boost duty cycle values (B1 and BDC1, for example). If "THRT" is selected, the main menu will display throttle reference values and throttle duty cycle values (T1 and TDC1, for example).

7. If "INPT" is set to "MAP", you must select the appropriate manifold absolute pressure sensor range. Scroll through main menu and select "MAP" and then select appropriate MAP sensor from "MAP" menu.

For Universal systems with the 45021 controller using the internal 100PSIA MAP sensor:

"INT" – Select this for use with the internal 100PSIA sensor and boost reference line

For vehicle specific systems with the 45020 controller using a factory MAP sensor:

"LBZ" –Chevy/GMC vehicles equipped with Duramax LBZ engine

"LB7" –Chevy/GMC vehicles equipped with Duramax LB7 engine

"LLY" –Chevy/GMC vehicles equipped with Duramax LLY engine

"LMM" –Chevy/GMC vehicles equipped with Duramax LMM engine

"LML" –Chevy/GMC vehicles equipped with Duramax LML engine

"D5.9" –Dodge vehicles equipped with Cummins 5.9L engine

"D6.7" –Dodge vehicles equipped with

Cummins 6.7L engine

"F6.0" –Ford vehicles equipped with Powerstroke 6.0L engine

"F6.4" –Ford vehicles equipped with Powerstroke 6.4L engine

8. Turn on your water-methanol system by scrolling through main menu and selecting "OCTL". Select desired control method from "OCTL" menu. See injection controller menu flow chart for menu structure.

"OFF" – Turns water-methanol injection system off (gauge features will still function)

"BST" – Controls system using boost pressure (Boosted applications only)

"THRT" – Controls system using percent throttle opening (Non-boosted applications only)

"EGT" – Controls system using exhaust gas temperature (Must be equipped with EGT thermocouple)

"E+B" – Controls system using exhaust gas temperature and boost pressure (Boosted applications only)

"E+T" – Controls system using exhaust gas temperature and percent throttle opening. (Non-boosted applications only)

"TEST" – Opens any connected solenoids and tests for system pressure, automatically turns pump off and closes solenoids when system reaches 40 PSI. If pump pressure switch is disconnected or 40 PSI output pressure switch point is not exceeded, pump will run at 50% duty cycle for 6 seconds with all solenoids open.

NOTICE: When using any control method based on controlling EGT, injecting distilled water only is recommended as a mixture with even a moderate methanol percentage can increase EGT at high injection rates.

9. Set desired display parameter by selecting "DISP" from main menu and then selecting desired display option.

"BST" – Displays manifold pressure in PSI (Boosted applications only)

"THRT" – Displays percent open throttle (Non-boosted applications only)

"EGT" – Displays exhaust gas temperature in degrees Fahrenheit (If equipped with EGT thermocouple)

"PDC" – Displays pump duty cycle in percent.

"S2ST" – Displays solenoid #2 status as on or off (If equipped with secondary solenoid)

10. Turn the injection activity LED on or off by selecting "LED" from main menu and then selecting "ON" or "OFF". When "ON", the Alert LED will flash with a frequency that corresponds to pump duty cycle when pump is running. When "OFF", the LED will not flash to indicate injection activity, but will still function normally to indicate any system errors.

11. To turn water-methanol system off, select "OCTL" from main menu and then select "OFF" from the "OCTL" menu.

Your injection system will now operate with the default setpoint values. To tailor the system's activation points and injection quantity to your specific engine, please refer to the advanced tuning section (below).

Advanced Tuning

The Banks Straight-Shot and Double-Shot injection systems offer a wide working injection flow range, as well as a wide range of user-selectable setpoints to control injection by. The goal of these wide flow- and adjustment ranges are to match a progressively increasing amount of injection to your engine's air-, load-, or EGT-curve. To vary injection quantity across a fixed size injection nozzle, supply pressure to the nozzle must be varied (as opposed to a typical automotive fuel injector, which uses a fixed supply pressure, and varies injection rate by switching the injector on

and off rapidly).

The Straight-Shot and Double-Shot systems vary supply pressure by increasing the duty cycle supplied to the injection pump. A low duty cycle supplies minimal power to the pump, and creates a low output pressure. Increasing the duty cycle increases the power supplied to the pump, generating an increased output pressure (and increased flow across the injection nozzle). Flow across the nozzle does not increase linearly with pressure, however - the injection controller and the injection pump compensate for this to a degree. To learn more, and view full nozzle flow and pump capacity curves, please visit our webpage at <http://www.bankspower.com/straightshot>

12. Set the first reference value (B1 or T1) to control when pump will turn on and first duty cycle value (BDC1 or TDC1) to control pump duty cycle at the first reference value. For boosted vehicles, reference values are boost pressure in PSI. For non-boosted vehicles, reference values are percent open throttle where 0 is closed throttle and 100 is wide open throttle.

12a. Scroll through main menu and select "B1" or "T1", depending on your application. Scroll through the values and select the reference value that you want the pump to turn on. If configuring a StraightShot system with only one injection stage, this setpoint should be above your typical light-load boost / throttle value. For DoubleShot systems where a small injection quantity is desired at light load, this should be set several PSI (or %) below your typical light-load boost / throttle value. The default setting is 10 PSI, which should be changed to a much higher setting (50% or more) if configuring a throttle-based system.

12b. Scroll through main menu and select "BDC1" or "TDC1", depending on your application. Scroll through the values and select the percentage of pump duty cycle at which the pump will run once triggered by the

first reference value. The default setting is 30% duty cycle - if this value is set too low, with too large of a nozzle, it can cause a low initial pump output pressure which can result in improper atomization at the nozzle. This may also trigger a Pump Output Error code if the 40 PSI pump output pressure switch is not triggered. However, if this value is set too high, the initial output pressure spike and injection 'hit' can be too severe and cause the engine to bog or misfire.

13. Repeat step 12 to set remaining reference values and accompanying duty cycle percentage values.

NOTICE: ***Straight-Shot systems have two reference values with accompanying duty cycle values. Double-Shot systems have four reference values with accompanying duty cycle values.***

EXAMPLE: For boosted applications, your water-methanol injection system will be inactive until boost pressure reaches the first boost reference value (B1), at which value first injection nozzle (or nozzle set) will begin to spray with a volumetric flow rate based on the first duty cycle value (BDC1). This injection nozzle (or injection nozzle set) will continue to spray while flow rate increases (with increasing pump duty cycle) until boost pressure reaches the second boost reference value (B2). At this value, the pump duty cycle will equal that of the second duty cycle (BDC2) percentage, and will remain at this duty cycle if boost continues to rise. Similarly, for Double-Shot systems the second injection nozzle (or second injection nozzle set) will begin spraying once boost pressure reaches B3 with a pump duty cycle equal to BDC3. Flow rate will increase until boost pressure reaches B4, at which value the pump duty cycle will equal that of BDC4.

For non-boosted applications, your

DEFAULT BOOST-BASED CONTROL POINTS - STRAIGHTSHOT SYSTEMS

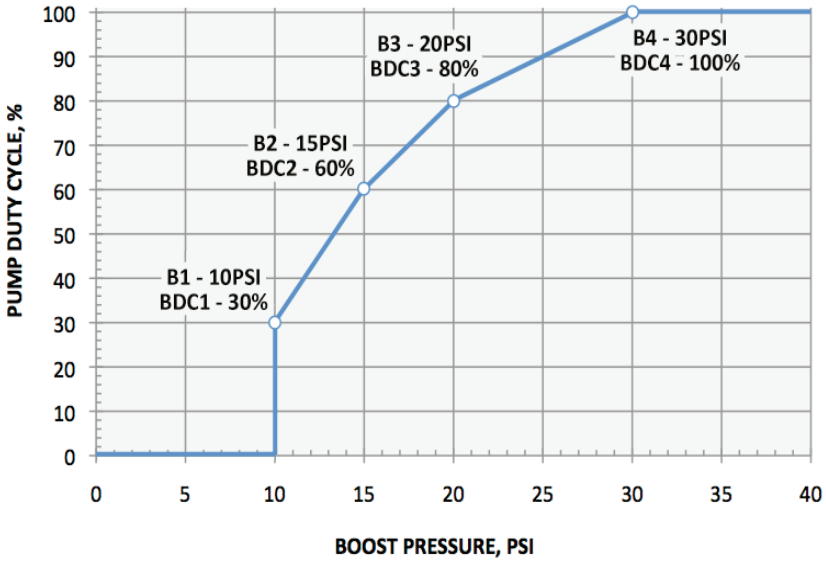

DEFAULT BOOST-BASED CONTROL POINTS - DOUBLESHOT SYSTEMS

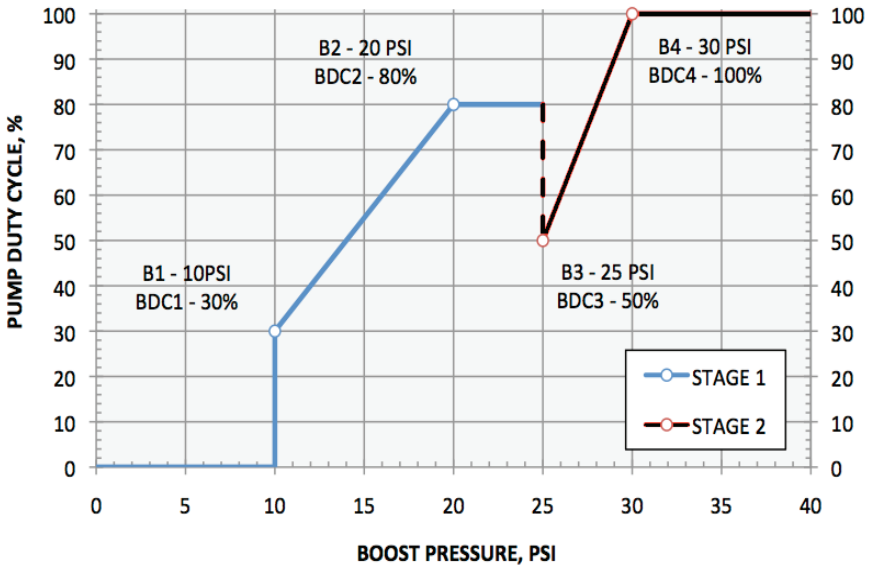

DEFAULT EGT-BASED CONTROL POINTS - STRAIGHTSHOT SYSTEMS

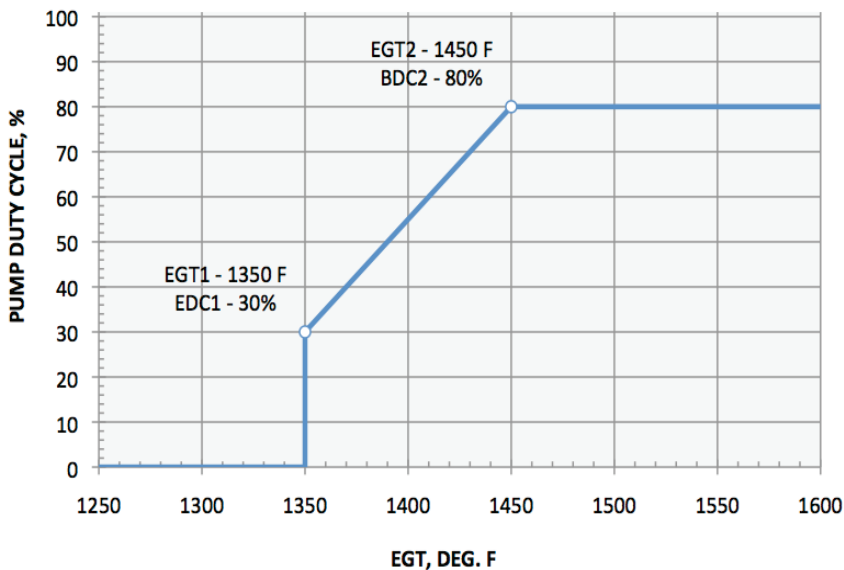

DEFAULT EGT-BASED CONTROL POINTS - DOUBLESLOT SYSTEMS

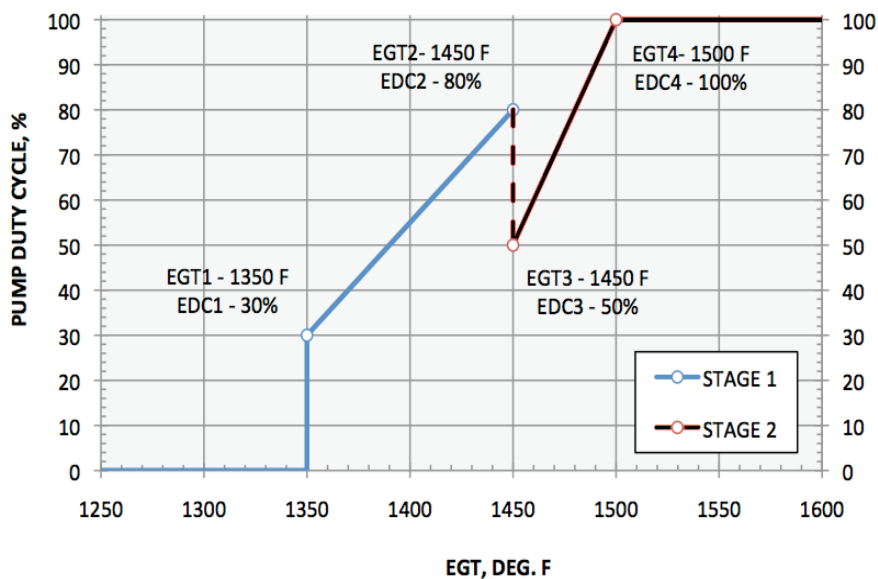

water-methanol injection system will be inactive until percent throttle opening reaches the first throttle reference value (T1), at which value first injection nozzle (or injection nozzle set) will begin to spray with a volumetric flow rate based on the first duty cycle value (TDC1). This injection nozzle (or injection nozzle set) will continue to spray while flow rate increases (with increasing pump duty cycle) until throttle opening reaches the second throttle reference value (T2). At this value, the pump duty cycle will equal that of the second duty cycle (TDC2) percentage, and will remain at this duty cycle if throttle percentage continues to rise. Similarly, for Double-Shot systems the second injection nozzle (or second injection nozzle set) will begin spraying once throttle opening reaches T3 with a pump duty cycle equal to TDC3. Flow rate will increase until throttle opening reaches T4, at which value the pump duty cycle will equal that of TDC4. Note that DC stays constant past T4 setpoint.

Test Drive

1. Drain water from windshield washer fluid reservoir or high capacity tank. Fill with Banks PowerBlend injection fluid.
2. Start vehicle and allow it to reach operating temperature before driving.
3. Ensure the Water-Methanol injection system is turned on (see System Setup and Testing, step 8).
4. Set injection controller to display pump duty cycle (see System Setup and Testing, step 9) to check if pump is running during driving conditions.
5. Drive normally in a minimal traffic area where you can safely monitor the injection controller. Once boost pressure reaches the first boost reference point, the injection controller should display the first pump duty cycle (BDC1). Pump duty cycle should increase as boost pressure increases, until boost

pressure reaches the second boost reference point (B2).

If injection controller only displays zero for pump duty cycle, the pump is not turning on. Ensure system is turned on. There may be an issue with the wiring or setup. Check all connections and check system setup on injection controller.

6. Park vehicle in a safe location and check for any leaks in Water-Methanol injection system.

System Tuning and Nozzle Selection

The Straight-Shot and Double-Shot systems come pre-packaged with several different nozzle options that cover a wide range of applications, but some controller setting optimization may help dial in your system for your intended usage.

When configuring for maximum performance, the largest kitted nozzles should be installed. If engine hesitation, misfiring, or early ignition (excessive combustion noise or rattling) is experienced, reduction of the commanded pump duty cycle, along with raising the boost reference points will reduce the injection quantity to help reduce this. If required, reduce the nozzle size to make large changes in injection quantity.

If typical fluid consumption is higher than desired, increase the initial boost reference point to decrease the frequency with which the controller activates (turning on only at higher load).

If more frequent injection is desired (for instance, when combating a constant high-EGT condition with distilled water, or offsetting diesel fuel usage with a water-methanol mixture), a proportionally small jet should be used, with a reduced initial boost reference point and low starting and final pump duty cycle values (a 'flat' response curve).



Parts List

45150	Straight-Shot - Methanol-Water Injection System - 2001-10 Chevy 6.6L, LB7-LMM	
45150-1	Base System, Straight-Shot MWI - Controller w/o Onboard MAP Sensor	1
45062	Injection Nozzle Kit-2, Methanol-Water Injection Systems	1
45085	Injection Nozzle, Methanol-Water, #4, 30lb/hr @ 100PSI, 100 Degree Full Cone	1
45087	Injection Nozzle, Methanol-Water, #7, 52lb/hr @ 100PSI, 100 Degree Full Cone	1
45090	Injection Nozzle, Methanol-Water, #14, 103lb/hr @ 100PSI, 100 Degree Full Cone	1
45122	Fitting, Nozzle, 90 Deg Swivel, 1/4" NPTF- 1/4" Push Lock - MWI	2
45123	Fitting, "Y", Female 1/4" Push-Lock, Black Nylon - MWI	1
91099	Teflon Tape, 1/2" X 100' -	1
45020	Module, Injection Controller - Methanol-Water Injection	1
45030	Pump Assy, High Volume, Methanol-Water Injection	1
45140	Tubing, 0.040" Wall, Nylon 11, Black-Methanol-Water Inj	10
62001	Cable Tie, Black, 6" -	12
62831	Pump Harness, Water-Methanol Injection Controller	1
62832	Signal Harness, Controller - Methanol-Water Injection	1
62834	Connector, T-Tap, Red - 22-18 Gauge	1
62838	Fuse Tap, Blade -	1
63001	Mounting Panel, One Gauge - Black, W/Fasteners	1
63006	Bracket, Module, Six-Gun/Bullet/WMI - Various Applications	1
91102	Washer, Sae Flat, Zinc - 1/4"	8
91761	Hex Bolt, Flange Head - 6Mm-1.00 X 45MM	4
91771	Nut, Nylock - M6 X 1.0, Zinc	4
91846	Washer, Internal Tooth Lock - #8	2
91868	Hex Nut, Zinc - 8-32	2
97651	Owner's Manual - Methanol-Water Injection System - Application Based	1
97651-A	Addendum, Owner's Manual-Schematic, MWI - Application Based	1
62832-10	Pigtail Harness, MAP, Water-Methanol Injection Controller, Duramax -LB7-LMM	1
Systems below have identical content as the system above with the exception of the Pigtail Harness		
45151	Straight-Shot - Methanol-Water Injection System - 2011-14 Chevy 6.6L, LML	
45150-1	Base System, Straight-Shot MWI - Controller w/o Onboard MAP Sensor	1
62832-11	Pigtail Harness, MAP, Water-Methanol Injection Controller, Duramax-LML	1
45155	Straight-Shot - Methanol-Water Injection System - 2003-07 Dodge 5.9L	
45150-1	Base System, Straight-Shot MWI - Controller w/o Onboard MAP Sensor	1
62832-20	Pigtail Harness, MAP, Water-Methanol Injection Controller, 2003-07 Dodge 5.9L	1
45156	Straight-Shot - Methanol-Water Injection System - 2007-14 Dodge 6.7L	
45150-1	Base System, Straight-Shot MWI - Controller w/o Onboard MAP Sensor	1
62832-21	Pigtail Harness, MAP, Water-Methanol Injection Controller, Dodge 6.7L	1
45160	Straight-Shot - Methanol-Water Injection System - 2003-07 Ford 6.0L	
45150-1	Base System, Straight-Shot MWI - Controller w/o Onboard MAP Sensor	1
62832-30	Pigtail Harness, MAP, Water-Methanol Injection Controller, Ford 6.0L	1
45161	Straight-Shot - Methanol-Water Injection System - 2008-10 Ford 6.4L	
45150-1	Base System, Straight-Shot MWI - Controller w/o Onboard MAP Sensor	1
62832-31	Pigtail Harness, MAP, Water-Methanol Injection Controller, Ford 6.4L	1
45170	Double-Shot - Methanol-Water Injection System - 2001-10 Chevy 6.6L, LB7-LMM	
45170-1	Base System, Double-Shot MWI - Controller w/o Onboard MAP Sensor	1
45040	Solenoid Kit, Methanol-Water Injection	1
45035	Solenoid, Methanol-Water Injection	1
45038	Bracket, Solenoid Mount, Single - Methanol-Water Injection	1
45120	Fitting, Straight, 1/4" NPTM - 1/4" Push Lock - MWI	2
91102	Washer, Sae Flat, Zinc - 1/4"	4
91110	Nut, Nylock - 1/4"-20	2
91118	Hex Bolt, Grade 5, Zinc - 1/4"-20 X 1"	2
91725	Screw - Button Head, Socket Cap - 10-32 X 3/8" - 18.8-S/5	2
91826	Washer, Int. Tooth Lock, Zinc - #10	2
45071	Injection Nozzle Kit-11, Methanol-Water Injection Systems	1
45084	Injection Nozzle, Methanol-Water, #3, 22lb/hr @ 100PSI, 100 Degree Full Cone	1
45087	Injection Nozzle, Methanol-Water, #7, 52lb/hr @ 100PSI, 100 Degree Full Cone	1
45088	Injection Nozzle, Methanol-Water, #10, 74lb/hr @ 100PSI, 100 Degree Full Cone	1
45090	Injection Nozzle, Methanol-Water, #14, 103lb/hr @ 100PSI, 100 Degree Full Cone	1
45122	Fitting, Nozzle, 90 Deg Swivel, 1/4" NPTF- 1/4" Push Lock - MWI	2
45123	Fitting, "Y", Female 1/4" Push-Lock, Black Nylon - MWI	2
91099	Teflon Tape, 1/2" X 100' -	1
45108	Thermocouple Kit - Methanol-Water Injection Systems	1
62001	Cable Tie, Black, 6" -	1
63042	Thermocouple, Pyrometer - Chevy, Dodge, Ford Pwr Sys	1
63060	Leadwire, Pyrometer, Electric - Various Applications	1
92273	Weld Bung, 1/4" NPT	1
45020	Module, Injection Controller - Methanol-Water Injection	1
45030	Pump Assy, High Volume, Methanol-Water Injection	1
45050	Check Valve, In-line - Methanol-Water Injection	1
45140	Tubing, 0.040" Wall, Nylon 11, Black-Methanol-Water Inj	25
62001	Cable Tie, Black, 6" -	12
62831	Pump Harness, Water-Methanol Injection Controller	1
62832	Signal Harness, Controller - Methanol-Water Injection	1
62837	Sub-Harness, Switch, Pump Pressure - Methanol-Water Injection	1
63001	Mounting Panel, One Gauge - Black, W/Fasteners	1
63006	Bracket, Module, Six-Gun/Bullet/WMI - Various Applications	1
91102	Washer, Sae Flat, Zinc - 1/4"	8
91761	Hex Bolt, Flange Head - 6Mm-1.00 X 45MM	4
91771	Nut, Nylock - M6 X 1.0, Zinc	2
91846	Washer, Internal Tooth Lock - #8	2
91868	Hex Nut, Zinc - 8-32	2
97651	Owner's Manual - Methanol-Water Injection System - Application Based	1
97651-A	Addendum, Owner's Manual-Schematic, MWI - Application Based	1
62832-10	Pigtail Harness, MAP, Water-Methanol Injection Controller, Duramax -LB7-LMM	1

Parts List (Continued)

45147 Tank Kit, 7 Gallon - Methanol-Water Injection			1
45098	Tank, 7 Gal, PE, Natural, with 1/4" FPT Fitting weld-on; 3.5" Top Vented Cap, Black, w/8" Tether		1
91103	Washer, Uss, Zinc - 1/4"		8
91110	Nut, Nylock - 1/4"-20		4
91120	Hex Bolt, Grade 5, Zinc - 1/4"-20 X 1 1/8"		4
91592	Strap, Mounting - MWI Tank, Large		2
Systems below have identical content as the system above with the exception of the Pigtail Harness			
45171	Straight-Shot - Methanol-Water Injection System - 2011-14 Chevy 6.6L, LML		
45170-1	Base System, Double-Shot MWI - Controller w/o Onboard MAP Sensor		1
62832-11	Pigtail Harness, MAP, Water-Methanol Injection Controller, Duramax-LML		1
45175	Straight-Shot - Methanol-Water Injection System - 2003-07 Dodge 5.9L		
45170-1	Base System, Double-Shot MWI - Controller w/o Onboard MAP Sensor		1
62832-20	Pigtail Harness, MAP, Water-Methanol Injection Controller, 2003-07 Dodge 5.9L		1
45176	Straight-Shot - Methanol-Water Injection System - 2007-14 Dodge 6.7L		
45170-1	Base System, Double-Shot MWI - Controller w/o Onboard MAP Sensor		1
62832-21	Pigtail Harness, MAP, Water-Methanol Injection Controller, Dodge 6.7L		1
45180	Straight-Shot - Methanol-Water Injection System - 2003-07 Ford 6.0L		
45170-1	Base System, Double-Shot MWI - Controller w/o Onboard MAP Sensor		1
62832-30	Pigtail Harness, MAP, Water-Methanol Injection Controller, Ford 6.0L		1
45181	Straight-Shot - Methanol-Water Injection System - 2008-10 Ford 6.4L		
45170-1	Base System, Double-Shot MWI - Controller w/o Onboard MAP Sensor		1
62832-31	Pigtail Harness, MAP, Water-Methanol Injection Controller, Ford 6.4L		1

Appendix A: Nozzle Flow Rates

BANKS PN	BANKS DESCRIPTION	STAMP#	FLOW RATE @ 100 PSI ΔP			HORSEPOWER POTENTIAL	
			GAL / HR	LB / HR*	CC / MIN	GAS (SUPPORTED)	DIESEL (ADDED)*
45081	Nozzle, Water-Methanol Injection,	0.75	0.75	6	47	23	3
45082	Nozzle, Water-Methanol Injection,	01	1	7	63	31	4
45083	Nozzle, Water-Methanol Injection,	02	2	15	126	63	8
45084	Nozzle, Water-Methanol Injection,	03	3	22	189	94	12
45085	Nozzle, Water-Methanol Injection,	04	4	30	252	125	16
45086	Nozzle, Water-Methanol Injection,	05	5	37	315	156	20
45087	Nozzle, Water-Methanol Injection,	07	7	52	442	219	28
45088	Nozzle, Water-Methanol Injection,	10	10	75	631	313	40
45089	Nozzle, Water-Methanol Injection,	12	12	90	757	375	48
45090	Nozzle, Water-Methanol Injection,	14	14	105	883	438	56

*BASED ON A 50/50 MIX OF METHANOL AND WATER

Appendix B: Pump Flow Rates

BANKS PN	BANKS DESCRIPTION	FLOW RATE @ 100 PSI ΔP			HORSEPOWER POTENTIAL	
		GAL / HR	LB / HR*	CC / MIN	GAS (SUPPORTED)	DIESEL (ADDED)*
45030	Pmp Assy, High Volume, Water-Methanol Inj.	43.7	327	2757	1250	175
45031	Pmp Assy, Low Volume, Water-Methanol Inj.	23.3	175	1470	750	90

*BASED ON A 50/50 MIX OF METHANOL AND WATER

Appendix C: Error Codes & Trouble Shooting

ERROR CODE	DESCRIPTION	TROUBLESHOOT
MAP ERR1	MAP sensor signal voltage too low or high	Check sensor connection and harness leads for shorts or broken connections. Refer to system schematic (P/N 97650-A or 97651-A).
SOL ERR2	Solenoid (either primary or 2nd stage) control current too high	Check solenoid harness connections and leads for shorts to ground. Refer to system schematic (P/N 97650-A or 97651-A).
FLD ERR3	Pump output pressure switch error	Typical indication of low / out of fluid state, check and fill reservoir. If condition does not correct, check connection and harness leads for shorts or broken connections. Refer to system schematic (P/N 97650-A or 97651-A). If no connection errors found, inspect downstream fluid plumbing from pump for leaks. If no leaks found, increase starting pump duty cycle to a higher value, as inadequate line pressure (<40 PSI) to trigger the pump output pressure switch may be present - common with larger nozzle(s).
EGT ERR4	EGT sensor connection problem	Check sensor connection and harness leads for shorts or broken connections. Refer to system schematic (P/N 97650-A or 97651-A).
STAT ERR5	System Status output line connection problem	Check harness connection and leads for shorts to ground. Refer to system schematic (P/N 97650-A or 97651-A).
PUMP ERR6	Pump overcurrent problem	Check pump harness connection and leads for shorts to ground. Refer to system schematic (P/N 97650-A or 97651-A).

Gale Banks Engineering
546 Duggan Avenue • Azusa, CA 91702
(626) 969-9600 • Fax (626) 334-1743

Product Information & Sales: (800) 438-7693
Customer Support: (888) 839-5600
Installation Support: (888) 839-2700

bankspower.com